

**Town of Poughkeepsie
Aboveground/Inground Pool
Building Permit Application**

Received:

Permit # _____

Property Address: Street: _____ City: _____ Zip: _____

Grid Number: _____ Zoning District: _____

Owners Name: _____	Phone: (H) _____	(W) _____
Address: Street: _____	City: _____	State: _____ Zip: _____

Builder : _____ Phone: _____

1) Attach Contractors workmans comp. C-105.2 or U-26.3 and Disability DB-120.1 or certificate of exempt

Address: Street: _____ City: _____ State: _____ Zip: _____

Project Description: _____

Electrician : _____	Phone: _____
Address: Street: _____	City: _____ State: _____ Zip: _____

Separate Electrical permits are required

Is the property located in a flood zone? Yes No *If yes, a floodplain development permit is required.*

Are any wetlands located on the property? Yes No

Please contact the Planning and Engineering Departments for information on wetlands and floodplains.

Percent Lot Coverage: _____ (all structures on lot) Estimated Cost: _____

The Owner/Applicant agrees to conform to all applicable laws of this jurisdiction, adhere to the plans and specifications affixed hereto and permit Building Department personnel to perform required inspections.

Applicant's Name: (If different than owner) _____ (attach letter of agency)

Owner/Applicant Signature: _____ Date _____

Application fee:	Aboveground : \$75.00	Inground: \$100.00	_____
Square footage of attached decks	_____ sq ft	X .20/sq ft	= _____
Receipt # _____	Total Fee		_____

Please attach the following:

SITE PLAN (see attached example)

- ___ Lot dimensions--all sides
- ___ Size and location of any easements or right-of-ways
- ___ Names and locations of all adjacent streets
- ___ Locations of proposed and existing structures
- ___ Setback dimensions--front, rear, and all sides
- ___ Outside building dimensions and distances between buildings on building site
- ___ Driveways, exterior stairs, landings, patios, and decks

BUILDING PLANS (two complete sets required)

- ___ Pool specifications.
- ___ Pool enclosure specifications. "Fence to code" not acceptable. See attached for pool enclosure specifications.

WATER CANNOT BE PLACED IN A POOL PRIOR TO THE ERECTION OF PERMANENT ENCLOSURE OR TEMPORARY ENCLOSURE APPROVED BY THE BUILDING DEPARTMENT
POOLS CANNOT BE USED PRIOR TO ISSUANCE OF CERTIFICATE OF COMPLIANCE

SITE PLAN
SAMPLE ONLY

*PLEASE NOTE ON SITE PLAN IF CORNER LOT

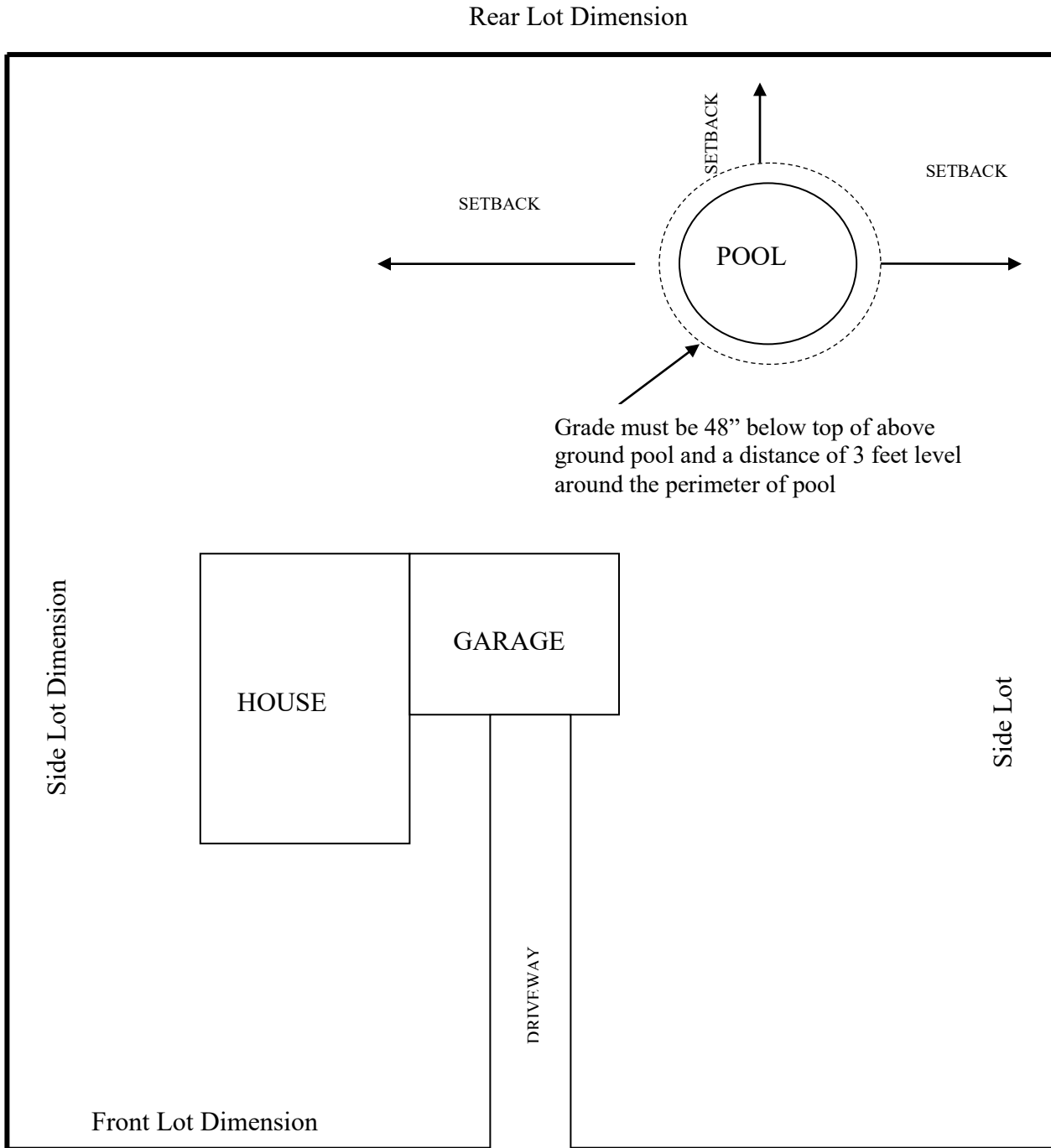

STREET NAME & NUMBER

NAME:
ADDRESS:
PHONE:

New York State Residential Code Pool Barrier Requirements

SECTION R326 SWIMMING POOLS, SPAS and HOT TUBS BARRIER REQUIREMENTS

[NY] R326.1 General The provisions of this section shall control the design and construction as well as substantial modification of swimming pools, spas and hot tubs installed in or on the lot of dwellings regulated under this code, and detached one- and two-family dwellings classified as Group R-3 and constructed under the *Building Code of New York State*.

Exception: Communal pools for the shared use of multiple townhouse units shall be regulated by the *Building Code of New York State*.

[NY] R326.1.1 Compliance with Other Sections. Swimming pools, spas and hot tubs shall comply with this section and other applicable sections of this code. The requirements of this section and of the other applicable sections of this code shall be in addition to, and not in replacement of or substitution for, the requirements of other applicable federal, state and local laws and regulations, including, but not necessarily limited to the requirements of Section 8003 (Federal swimming pool and spa drain cover standard) of Title 15 of the United States Code (CPSC 15 USC 8003), where applicable.

[NY] R326.2 Definitions. For the purpose of these requirements, the terms used shall be defined as follows and as set forth in Chapter 2.

BARRIER, PERMANENT. A fence, the walls of a permanent structure, any other structure or combination thereof which completely surrounds the swimming pool and sufficiently obstructs access to the swimming pool.

BARRIER, TEMPORARY. An approved temporary fence, permanent fence, the walls of a permanent structure, any other structure, or any combination thereof that sufficiently prevents access to the swimming pool by any person not engaged in the installation or construction of the swimming pool during its installation or construction.

HOT TUB. See "Spa."

RESIDENTIAL. That which is situated on the premises of dwellings regulated under this code, and detached dwellings classified as R-3 and constructed under the *Building Code of New York State*.

SPA. A portable or non-portable structure intended for recreational or therapeutic bathing, in which all controls, water heating and water-circulating equipment are an integral part of the product. Spas are shallow in depth and are not designed for swimming or diving.

SUBSTANTIAL DAMAGE. For the purpose of determining compliance with the pool alarm provisions of this section, damage of any origin sustained by a swimming pool, whereby the cost of restoring the swimming pool to its before-damaged condition would equal or exceed 50 percent of the market value of the swimming pool before the damage occurred.

SUBSTANTIAL MODIFICATION. For the purpose of determining compliance with the pool alarm provisions of this section, any repair, alteration, addition or improvement of a swimming pool, the cost of which equals or exceeds 50 percent of the market value of the swimming pool before the improvement or repair is started. If a swimming pool has sustained substantial damage, any repairs are considered substantial modification regardless of the actual repair work performed.

SUCTION OUTLET. A fitting, fitting assembly, cover/ grate, sump, and related components that provide a localized low-pressure area for the transfer of water from a swimming pool.

SWIMMING POOL. Any structure, basin, chamber or tank which is intended for swimming, diving, recreational bathing or wading and which contains, is designed to contain, or is capable of containing water more than 24 inches (610 mm) deep at any point. This includes in-ground, above-ground and on-ground pools, indoor pools, hot tubs, spas, and wading pools.

SWIMMING POOL, INDOOR. A swimming pool which is totally contained within a structure and surrounded on all four sides by the walls of the enclosing structure.

SWIMMING POOL, OUTDOOR. Any swimming pool which is not an indoor pool.

[NY] R326.3 Compliance with Other Standards

[NY] R326.3.1 In-Ground Pools. In-ground pools shall be designed and constructed in conformance with ANSI/APSP/ICC 5 (American National Standard for Residential In-ground Swimming Pools, 2011).

[NY] R326.3.2 Above-Ground and On-Ground Pools. Above-ground and on-ground pools shall be designed and constructed in conformance with ANSI/APSP/ICC 4 (American National Standard for Aboveground/On-ground Residential Swimming Pools, 2012).

[NY] R326.3.3 Permanently Installed Spas and Hot Tubs. Permanently installed spas and hot tubs shall be designed and constructed in conformance with ANSI/ APSP/ICC 3 (American National Standard for Permanently Installed Residential Spas and Swim Spas, 2014).

[NY] R326.3.4 Portable Spas and Hot Tubs. Portable spas and hot tubs shall be designed and constructed in conformance with ANSI/APSP/ICC 6 (American National Standard for Residential Portable Spas and Swim Spas, 2013).

[NY] R326.4 Barriers, Application. The provisions of this section shall control the design of barriers for swimming pools, spas and hot tubs. These design controls are intended to provide protection against potential drowning and near-drowning by sufficiently preventing access to swimming pools, spas and hot tubs by persons outside the property, persons within the dwelling, and persons in other parts of the property not contained within the pool enclosure.

[NY] R326.4.1 Temporary Barriers. An outdoor swimming pool shall be surrounded by a temporary barrier during installation or construction that shall remain in place until a permanent barrier in compliance with Section R326.4.2 is provided.

Exception:

- Above-ground or on-ground pools where the pool structure constitutes a barrier in compliance with Section R326.4.2.9.
- Spas or hot tubs with a safety cover which complies with ASTM F1346, provided that such safety cover is in place during the period of installation or construction of such hot tub or spa. The temporary removal of a safety cover as required to facilitate the installation or construction of a hot tub or spa during periods when at least one person engaged in the installation or construction is present is permitted.

[NY] R326.4.1.1 Height. The top of the temporary barrier shall be at least 48 inches (1219 mm) above grade measured on the side of the barrier which faces away from the swimming pool.

[NY] R326.4.1.2 Replacement by a Permanent Barrier

A temporary barrier shall be replaced by a complying permanent barrier within either of the following periods:

- 90 days of the date of issuance of the building permit for the installation or construction of the swimming pool; or
- 90 days of the date of commencement of the installation or construction of the swimming pool.

[NY] R326.4.1.2.1 Replacement Extension. Subject to the approval of the *building official*, the time period for completion of the permanent barrier may be extended for good cause, including, but not limited to, adverse weather conditions delaying construction.

[NY] R326.4.2 Permanent Barriers. Swimming pools shall be completely enclosed by a permanent barrier complying with Sections R326.4.2.1 through R326.4.2.6.

[NY] R326.4.2.1 Barrier Height and Clearances. The top of the barrier shall be no less than 48 inches (1219 mm) above grade measured on the side of the barrier that faces away from the swimming pool. The vertical clearance between grade and the bottom of the barrier shall be not greater than 2 inches (51 mm) measured on the side of the barrier that faces away from the swimming pool. Where the top of the pool structure is above grade, the barrier may be at ground level, or mounted on top of the pool structure. Where the barrier is mounted on top of the pool structure, the barrier shall comply with Sections R326.4.2.2 and R326.4.2.3.

[NY] R326.4.2.2 Solid Barrier Surfaces. Solid barriers which do not have openings shall not contain indentations or protrusions except for normal construction tolerances and tooled masonry joints.

[NY] R326.4.2.3 Closely Spaced Horizontal Members. Where the barrier is composed of horizontal and vertical members and the distance between the tops of the horizontal members is less than 45 inches (1143 mm), the horizontal members shall be located on the swimming pool side of the fence. Spacing between vertical members shall not exceed 1³/₄ inches (44 mm) in width. Where there are decorative cutouts within vertical members, spacing within the cutouts shall be not greater than 1³/₄ inches (44 mm) in width.

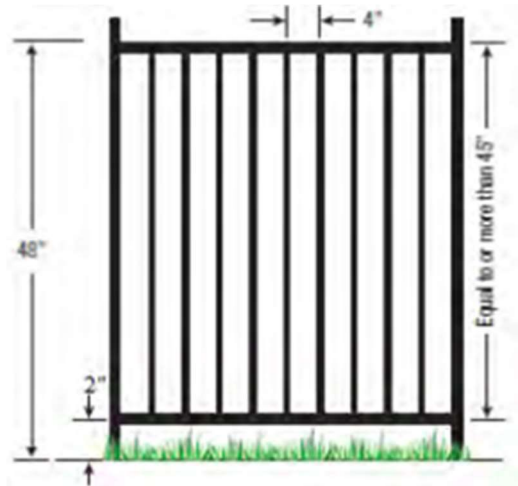

[NY] R326.4.2.4 Widely Spaced Horizontal Members. Where the barrier is composed of horizontal and vertical members and the distance between the tops of the horizontal members is 45 inches (1143 mm) or more, spacing between vertical members shall be not greater than 4 inches (102 mm). Where there are decorative cutouts within vertical members, spacing within the cutouts shall be not greater than 1³/₄ inches (44 mm) in width.

[NY] R326.4.2.5 Chain Link Dimensions. Maximum mesh size for chain link fences shall be a 2¹/₄ inch (57 mm) square, unless the fence has vertical slats fastened at the top or the bottom which reduce the openings to not more than 1³/₄ inches (44 mm).

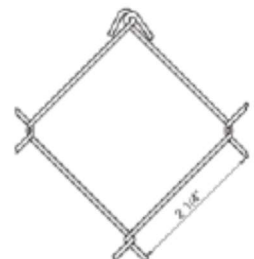

[NY] R326.4.2.6 Diagonal Members. Where the barrier is composed of diagonal members, the maximum opening formed by the diagonal members shall be not greater than $1\frac{3}{4}$ inches (44 mm).

[NY] R326.4.2.7 Gates. Gates shall comply with the requirements of Sections R326.4.2.1 through R326.4.2.6, and with the following requirements;

[NY] R326.4.2.7.1 Self-Closing and Opening Configuration. All gates shall be self-closing. In addition, if the gate is a pedestrian access gate, the gate shall open outward, away from the pool.

[NY] R326.4.2.7.2 Latching. All gates shall be self-latching, with the latch handle located within the enclosure (i.e., on the pool side of the enclosure) and at least 40 inches (1016 mm) above grade. In addition, if the latch handle is located less than 54 inches (1372 mm) from grade, the latch handle shall be located at least 3 inches (76 mm) below the top of the gate, and neither the gate nor the barrier shall have any opening greater than 0.5 inch (12.7 mm) within 18 inches (457 mm) of the latch handle.

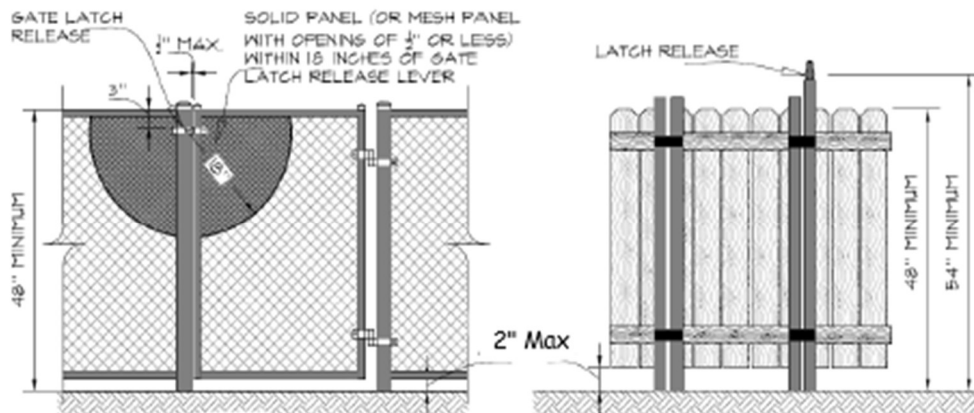

[NY] R326.4.2.7.3 Locking. All gates shall be securely locked with a key, combination or other child-proof lock sufficient to prevent access to the swimming pool through such gate when the swimming pool is not in use or supervised.

[NY] R326.4.2.8 Dwelling Wall as Barrier. A wall or walls of a dwelling may serve as part of the barrier, provided that the wall or walls meet the applicable barrier requirements of Sections R326.4.2.1 through R326.4.2.6, and one of the following conditions shall be met:

1. a. Doors with direct access to the pool through that wall shall be equipped with an alarm that produces an audible warning when the door and/or its screen, if present, are opened. The alarm shall be listed in accordance with UL 2017. The audible alarm shall activate within 7 seconds and sound continuously for a minimum of 30 seconds after the door and/or its screen, if present, are opened and be capable of being heard throughout the house during normal household activities. The alarm shall automatically reset under all conditions. The alarm system shall be equipped with a manual means, such as touch pad or switch, to temporarily deactivate the alarm for a single opening. Deactivation shall last for not more than 15 seconds; and

- b. Operable windows in the wall or walls used as a barrier shall have a latching device located no less than 48 inches above the floor. Openings in operable windows shall not allow a 4-inch-diameter (102 mm) sphere to pass through the opening when the window is in its largest opened position; and
 - c. Where the dwelling is wholly contained within the pool barrier or enclosure, alarms shall be provided at every door with direct access to the pool; or
2. Other approved means of protection, such as self-closing with self-latching devices, so long as the degree of protection afforded is not less than the protection afforded by Item 1 described above.

[NY] R326.4.2.8.1 Alarm Deactivation Switch Location. Where an alarm is provided, the deactivation switch shall be located 54 inches (1372 mm) or more above the threshold of the door.

[NY] R326.4.2.9 Pool Structure as Barrier. Where an above-ground pool structure is used as a barrier, or where the barrier is mounted on top of the pool structure, the structure shall be designed and constructed in compliance with ANSI/APSP/ICC 4 and meet the applicable barrier requirements of Sections R326.4.2.1 through R326.4.2.8. Where the means of access is a ladder or steps, one of the following conditions shall be met:

The ladder or steps shall be capable of being secured, locked or removed to prevent access. When the ladder or steps are secured, locked or removed, any opening created shall not allow the passage of a 4-inch-diameter (102 mm) sphere; or

The ladder or steps shall be surrounded by a barrier which meets the requirements of Sections R326.4.2.1 through R326.4.2.8.

Above ground pools on sloped site where the pool wall is used as the barrier

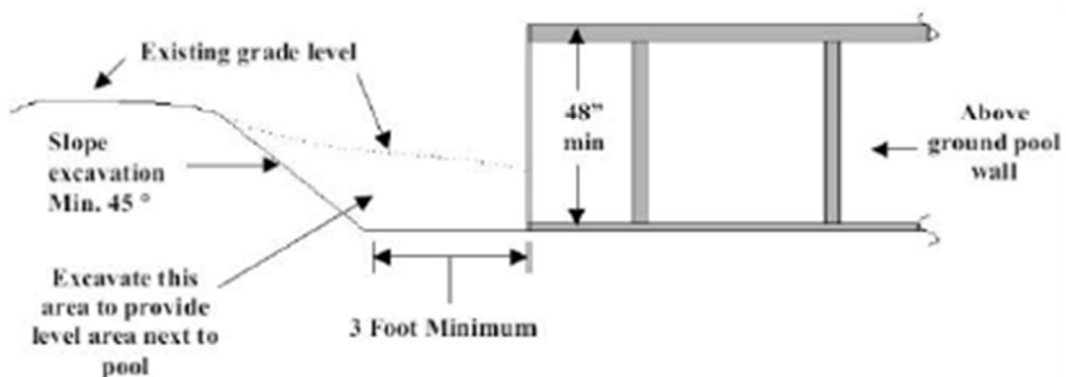

[NY] R326.4.3 Indoor Swimming Pool. Walls surrounding an indoor swimming pool shall comply with Section R326.4.2.8.

[NY] R326.4.4 Prohibited Locations. Barriers shall be located so as to prohibit permanent structures, equipment or similar objects from being used to climb the barrier.

[NY] R326.7 Swimming Pool and Spa Alarms, Applicability. A swimming pool or spa installed, constructed or substantially modified after December 14, 2006, shall be equipped with an approved pool alarm. Pool alarms shall comply with ASTM F2208 (Standard Specification for Pool Alarms), and shall be installed, used and maintained in accordance with the manufacturer's instructions and this section.

Exception:

- A hot tub or spa equipped with a safety cover which complies with ASTM F1346.
- A swimming pool (other than a hot tub or spa) equipped with an automatic power safety cover which complies with ASTM F1346.

[NY] R326.7.1 Multiple Alarms. A pool alarm must be capable of detecting entry into the water at any point on the surface of the swimming pool. If necessary to provide detection capability at every point on the surface of the swimming pool, more than one pool alarm shall be provided.

[NY] R326.7.2 Alarm Activation. Pool alarms shall activate upon detecting entry into the water and shall sound poolside and inside the dwelling.

[NY] R326.7.3 Prohibited Alarms. The use of personal immersion alarms shall not be construed as compliance with this section.